



Statens vegvesen

Etatsprogrammet Moderne vegtunneler 2008 - 2011

Road Tunnel Strategy Study 2

Statens vegvesens rapporter

Nr. 154



Vegdirektoratet
Trafikksikkerhet, miljø- og teknologiavdelingen
Tunnel og betong
August 2012

Tittel

Etatsprogrammet Moderne vegtunneler
2008 - 2011

Title**Undertittel**

Road Tunnel Strategy Study 2

Subtitle**Forfatter**

Basler & Hofmann AG
Norconsult AS

Author**Avdeling**

Trafikksikkerhet, miljø- og teknologiavde-
lingen

Department

Trafikksikkerhet, miljø- og teknologiavde-
lingen

Seksjon

Tunnel og betong

Section

Tunnel og betong

Prosjektnummer

602182

Project number**Rapportnummer**

Nr. 154

Report number

No. 154

Prosjektleder

Harald Buvik

Project manager**Godkjent av****Approved by****Emneord**

Etatsprogram, Moderne vegtunneler, Tun-
nel, Strategi

Key words**Sammendrag**

Rapporten er en gjennomgang av tunnel-
standarden i Sveits og de anbefalinger som
sveitsiske myndigheter gir når det gjelder
bergsikring og tunnelkledninger. Dette som
en sammenligning til de forslagene til ny
byggestrategi for norske vegtunneler som
Etatsprogrammet har kommet fram til.

Summary

Antall sider

Dato 21.august 2012

Pages

Date

Road Tunnel Strategy Study

Auxiliary report

Customer

Norconsult AS
Vestfjordgaten 4
1338 Sandvika
Norway

Date

1st of July 2010



Imprint

Date

1st of July 2010

Report No.

B 4684.101 rev. 0

Prepared by

MAT, BCA, STE, EA

Basler & Hofmann AG
Consulting Engineers

Forchstrasse 395

Postfach

CH-8032 Zürich

T +41 44 387 11 22

F +41 44 387 11 00

Bachweg 1

Postfach

CH-8133 Esslingen

T +41 44 387 15 22

F +41 44 387 15 00

Mailing list

Lars-Petter Nesvåg
Morten Knudsmoen

Table of Contents

1.	Introduction	6
1.1	General	6
2.	Final lining	7
2.1	Shotcrete	7
2.1.1	Shotcrete classes	8
2.1.2	Shotcrete mix	8
2.1.3	Strength development	10
2.1.4	Testing / Measurement methods	11
2.1.5	Shotcrete with increased fire resistance	13
2.2	Prefabricated concrete elements	13
2.2.1	Production	13
2.2.2	Composition	13
2.2.3	Strength development	14
2.2.4	Placing	14
2.2.5	Special requirements	14
2.3	In Situ cast concrete	14
2.3.1	Final lining made of in-situ concrete	15
2.3.2	Strength development	15
2.3.3	Testing of Concrete Properties	17
2.3.4	Concrete with enhanced Fire Resistance	19
3.	Sealing	21
3.1	General	21
3.2	Sealing concepts	22
3.3	Polymer-bitumen membranes	22
3.4	Plastic membranes	22
3.4.1	Design requirements	22
3.4.2	Plastic membranes with shotcrete lining	23
3.5	Sprayable membranes	23
3.6	Sealing of the prefabricated concrete segment (tubbings)	25
4.	Repair or replacement of damaged membranes	26
4.1	General	26
4.2	Replacement of the sealing in a double shell railway tunnel	26
4.3	Double layered sealing membrane	28
5.	Typical cross sections	29
5.1	General	29
5.2	Cross section of Norwegian tunnel (Vegdirektoratet)	29
5.3	Cross sections of Swiss road tunnels	30
5.3.1	According to the SIA standards	30

5.4	Rules for the selection of the ventilation system	33
5.5	Examples of executed Road Tunnels	35
5.6	Swiss standards concerning emergency places and SOS - niches	37
5.6.1	emergency places	37
6.	Final remarks	41

1. Introduction

1.1 General

Recent incidents in existing road tunnels in Norway like damages due to frost effects or damages to the inner lining as a consequence of falling rocks have led to a reconsideration of the existing design standards. As a basis of comparison, the recommendations of the Swiss tunnel standards will be analysed. In this auxiliary report additional questions asked by the Statens Vegvesen will be answered.

The content of the main report is listed below.

1. Introduction
2. Swiss – Tunnel approach
3. Geology
4. Drill and Blast
5. Lining methods
6. Frost and Salt protection
7. Fire protection of Road Tunnels
8. Ventilation
9. Life time of Roadtunnel Elements
10. Costs
11. Final remarks

2. Final lining

In Switzerland tunnels are usually built for a life time of over 100 years. This means that regulations for primary support, dewatering, sealing and waterproofing systems as well as for the final lining have to fulfill high requirements.

Final lining in Switzerland is required in all road and railway tunnels, especially in soft ground. The purpose of a final lining in most of the cases are

- _ the protection of the sealing membrane,
- _ bearing external water pressure,
- _ provision of an internal finishing suitable for painting (brightness, escape and safety labelling)
- _ mounting of the tunnel equipment (ventilation, traffic signs, etc.).

The principal materials and construction methods for final lining tunnels are:

- _ shotcrete
- _ in-situ concrete,
- _ prefabricated concrete segments (tubbings)

2.1 Shotcrete

_ General

Shotcrete construction is used in many different types of projects. The flexibility and economy of this method have a positive effect in complex underground constructions like crossing of tunnels, connection of SOS niches, etc. In most of the cases it is applied manually but if a large quantity is needed, spraying robots are often used.

Shotcrete application systems are also permanently installed on tunnel boring machines (ripper TBM). The concrete spraying robots used for this purpose are designed and built to the customers needs and specifications and mounted onto the TBM.

There are two different shotcrete processes:

- _ dry process shotcrete
- _ wet process shotcrete



Fig. 2.1: Dry shotcrete application



Fig. 2.2: Wet shotcrete with robot

2.1.1 Shotcrete classes

The properties of the concrete change considerably during its rapid hydration. Shotcrete has a higher cement content and contains more sand in comparison with conventional concrete. It is immediately loaded when sprayed on the exposed ground, resulting in pronounced creep and increased shrinkage. Shotcrete also exhibits a non-linear stress-strain behaviour in compression.

Shotcrete classes

in accordance with Swiss standard SIA 198

shotcrete

term	SC 2	SC 3	SC 4	SC 5	SC 6	SC 7
According to SN EN 206-1						
compression strength	C25/30	C25/30	C30/37	C30/37	C30/37	C35/45
application	immediate excavation support	additional excavation support	excavation support for single shell tunnels, reinforced	final lining for single shell tunnels, reinforced or unreinforced		

Fig 2.3 Shotcrete classes SIA 198

2.1.2 Shotcrete mix

_ Cement

Cement causes hydraulic setting and is therefore partly responsible for the mechanical properties of the set shotcrete. As an additional requirement cement for shotcrete must always start to set extremely quickly and give a very high early strength.

_ Aggregates

The total fines content of a shotcrete mix depends on many different factors and can be assessed as follows. The maximum aggregate size is 16 mm.

Aggregate	0 – 8 mm	0 – 16 mm
Round	500 kg/m³	450 kg/m³
Crashed	525 kg/m³	475 kg/m³

Fig 2.4 Total fines content in one m3 shotcrete

_ Additives

Additives are used in shotcrete for a variety of requirements and therefore differ considerably in characteristics:

- _ to supplement the fines balance $\leq 0,125$ mm (filler)
- _ to improve specific durability properties (strength/resistance to solvent or driving forces)
- _ to increase the water retention capacity (mix stabilisation)
- _ to reduce the pump pressure during delivery (lubricant)

Many different types of fines are used. An important factor in selection of admixtures is the economy and therefore local availability of these very fine materials, which is why different types are preferred in different localities.

Effect	Additives type	Remarks
Hydraulic	Cement	Cement-type and -quantity influence the workability and strength development
Latent hydraulic	Slag	Slow down the strength development and increase the durability
Pozzolanic	Microsilica Fly ash	Improve the durability, increase the bonding behaviour and with it the mechanical properties . Reduce the pH value of the concrete interstitial water and should therefore be limited in quantity.
Inert	Stone dust (e.g. limestone filler)	Do not themselves develop strength but help by improving the particle matrix

Fig 2.5
Effects of additives for shotcrete and mortar

_ Shotcrete mix design – example

Wet-mix shotcrete 0 – 8 mm dense-flow process		
Cement	425 kg	135 l
<i>SikaFume® -HR/-TU</i>	20 kg	9 l
<i>Sika®Tard (FM) / Sika®ViscoCrete® (FM)</i>	1.2 %	
<i>Sika®Tard-930 (VZ)</i>	0.3 %	
Aggregate:		
0 – 4 mm with 4 % inherent moisture (60 %)	967 kg	358 l
4 – 8 mm with 2 % inherent moisture (40 %)	791 kg	293 l
Added water (W/C = 0.47)	155 kg	155 l
Air voids (4.5 %)		45 l
Steel fiber	40 kg	5 l
Shotcrete		1000 l
Density per m³	2398 kg	
1 m³ applied shotcrete gives set on the wall		
Accelerated with <i>Siguna®AF Liquid</i> (rebound 6 – 10 %) 0.90 – 0.94 m³		
Cement content in shotcrete 450 – 470 kg/m³		
Steel fiber content in shotcrete appr. 30 kg/m³		

Fig. 2.6: Wet shotcrete mix design, dense-flow process

Dry-mix shotcrete 0 – 8 mm	
Cement	280 kg
<i>SikaFume®-HR/-TU</i>	20 kg
<i>Sika®Tard-930 (VZ) 0,3 %</i>	
55 % 0 – 4 mm with 4 % inherent moisture	ca. 680 kg
45 % 4 – 8 mm with 2 % inherent moisture	ca. 560 kg
Dry mix moist m³	*ca. 1540 kg
*must be checked by a yield test	
Cement content	
For 1000 litres dry mix, 280 kg cement is added to 800 litres aggregate	
For 1250 l litres dry mix, 350 kg cement is added to 1000 litres aggregate	
Shotcrete from 1 m³ dry mix gives on the wall	
Accelerated with <i>Siguni®AF Powder</i> (rebound 16 – 20 %) 0.58 – 0.61 m³	
Accelerated with <i>Siguni®AF Liquid</i> (rebound 20 – 25 %) 0.55 – 0.58 m³	
Cement content in the shotcrete appr. 450 kg/m³	

Fig 2.7: Dry shotcrete mix design

2.1.3 Strength development

_ Early strength development

Early strength

For the evaluation of the shotcrete properties quality SN EN 206-1 standard is used in Switzerland.

The early strength classes J1, J2 and J3 from the Austrian Concrete Society: Code of Practice for Shotcrete, are also often used in Europe to define the early strength.

Early strength class J1

Application in thin layers on a dry substrate with no structural requirements.

Early strength class J2

Application in thicker layers, including overhead, at a high output, with low water pressure and with load on the newly shotcrete from subsequent works.

Early strength class J3

Application for consolidation works or under high water pressure. Should only be used for special situations due to increased dust formation.

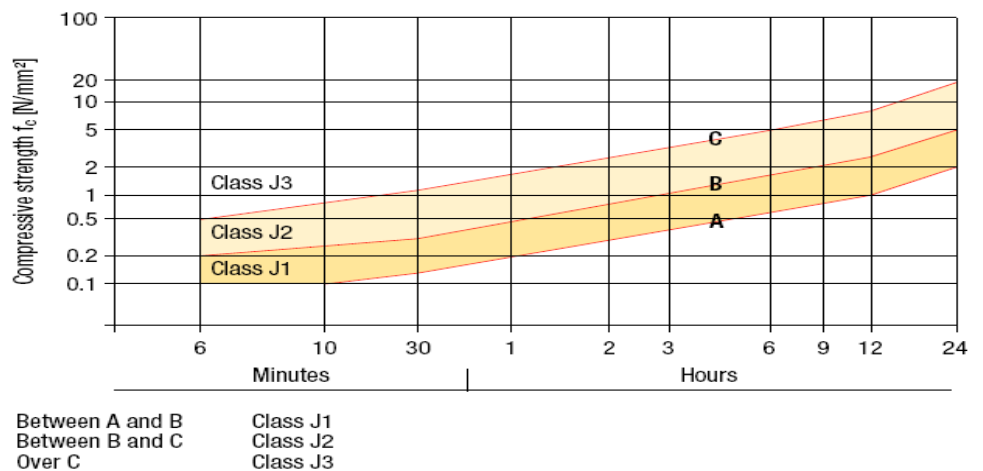

Fig 2.8: Code of Practice for Shotcrete, Austrian Concrete Society

_ Final strength

Final strength

Alongside the very early and early strength required specifically for shotcrete, there are mechanical requirements for the hardened shotcrete, just as there are for conventional concrete, generally after 28 days. The level of strength is based on the engineering by the design requirements. The compressive strength is measured on cores taken from the structure or from sprayed panels.

The properties of the shotcrete are tested on samples taken directly from the structure or from panels sprayed parallel to the application under conditions of maximum similarity and then taken for sampling without destroying the structure. Sprayed panels with defined dimensions are also used for the plate test to determine the tensile strengths and the ductility of the reinforced shotcrete.

2.1.4 Testing / Measurement methods

Three methods are used to measure the strength development of shotcrete. They enable the development of mechanical resistance to be evaluated by practical means.

Strength development stage	Test method	Range of application
Very early strength	Needle penetration method	0 to ca. 1 N/mm ²
Early strength	Bolt firing method	ca. 1 to ca. 15 N/mm ²
Strength	Core compressive strength	over ca. 10 N/mm ²

Fig 2.9
Testing methods

Very early strengths

This method measures the force required to press a steel needle with defined dimensions into the shotcrete. The strength can be deduced from this resistance. This method is suitable for strength levels immediately after application of up to 1 N/mm².



_ Determination by the pull-out force of bolts
_ ~ 0 - 1.2 N/mm²

Fig. 2.10
Needle penetration method

Early strengths

With this method (Dr. Kusterle's bolt firing method), standardised nails are fired into the shotcrete with a Hilti DX 450L gun. The depth of penetration and pull-out force are determined to obtain the compressive strength. The change in strength can be allowed for by using different nails and ammunition. This method has been simplified by Dr. G. Bracher so that the strength can be determined directly from the depth of penetration.



- Determination of the impression depth (I) and pull-out force (P) of nails shot with a HILTI DX 450L shot bolt machine (load and nail size are standard)

~ 1 - 15 N/mm²

Fig. 2.11
Bolt firing method

Strength development

Over about 10 N/mm², the compressive strength can be obtained by taking cores directly under a compression tester. This method is used mainly to check the required final strength after 28 days.

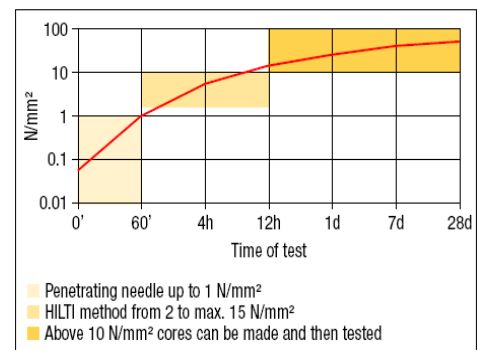
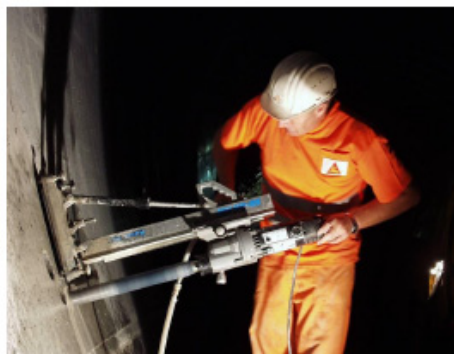

- Above 10 N/mm² cores can be made and then tested

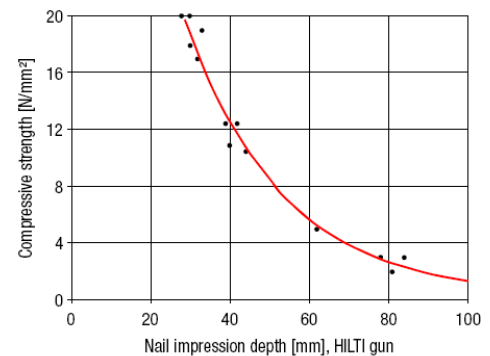

Fig. 2.12: Core testing

Fire protection

2.1.5 Shotcrete with increased fire resistance

The fire resistance of shotcrete and mortar can be increased by complex mix formulations. These materials are generally supplied as ready mix mortars and are very expensive. It is then possible to meet virtually any fire resistance specification. To obtain these formulations, all the components must be selected for their fire resistance, which results in specific solutions for the aggregate in particular.

However, the fire resistance can also be considerably improved at low cost by including a wearing course. By adding a special plastic fibre (PP fibre), the temperature drop in a thin wearing course can be guaranteed; it has to be replaced after a fire.

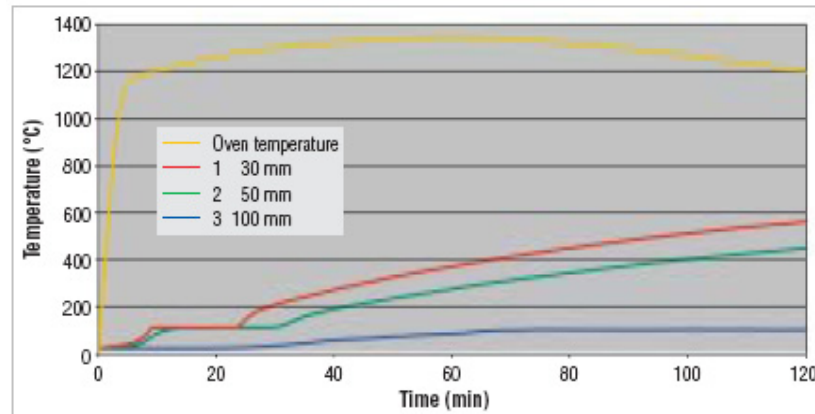

Fig 2.13: Fire resistant shotcrete with PP fibres tested by the RWS / TNO specification

2.2 Prefabricated concrete elements

– General

Mechanical tunnelling methods (TBM) in unstable rock and loose soil use prefabricated concrete elements (tubbings) that are immediately load bearing as a primary support to the fullface excavated tunnel section.

2.2.1 Production

In most of the cases concrete is manufactured on site at the factory by an accredited batching plant according to an approved mix design. Slump tests are performed on every batch before casting of segments. Overhead concrete skips pour concrete into the steel shutters whilst vibrating the moulds. In order to prevent segregation, vibration is not permitted to exceed 300 seconds per mould per hour.

2.2.2 Composition

– Aggregate

Normally 0–32 mm in the grading range according to EN 480-1

– Cement

Cement content 325 or 350 kg/m³

CEM I 42.5 or 52.5

Assessment graph

2.2.3 Strength development

Due to the large numbers required and heavy weight (up to several tonnes each), tunnel segments are almost always produced near the tunnel portal in specially installed precasting facilities. They have to meet high accuracy specifications. Therefore heavy steel formwork is required.

Because striking takes place after only 5–6 hours and the concrete must already have a compressive strength of $>15 \text{ N/mm}^2$, accelerated strength development is essential. The segments require to have a compressive cube strength (150mmx150mm) of at least 50 MPa at 28 days. Before placing the elements in the tunnel, the concrete segment strength requirement is 55 MPa. Therefore, three extra test cubes are cast for each batch of segments and tested after 56 days to check that the compressive strength has reached 55 MPa.

There are several methods for this. In the autoclave (heat backflow) process, the concrete is heated to 28–30 °C during mixing (with hot water or steam), placed in the form and finished. It is then heated for about 5 hours in an autoclave at 50–60 °C to obtain the necessary demoulding strength. To avoid the development of ettringite crystals that reduces the life time, the maximum temperature inside the concrete element must not exceed 60 °C.

2.2.4 Placing

The fresh concrete mix tends to stiffen rapidly due to the high temperature, making correct compaction and finishing of the surface demanding.

Due to the rapid industrialized process, a plastic fresh concrete consistence can be used. The desired initial strength can only be obtained by a low water/cement ratio (< 0.48), pre heating and an increased cement content.

2.2.5 Special requirements

The newly demoulded segments must be cured by covering or spraying with a curing agent.

2.3 In Situ cast concrete

– General

Concrete cast in situ is site-mixed or ready-mixed concrete which remains in its final position in the structure after being placed in the formwork. The ready-mix plant facilities have become widespread in many markets that the contractor can be supplied quickly and reliably.

A facility on the construction site still offers economic and logistic advantages where concrete is required continuously.

2.3.1 Final lining made of in-situ concrete

Typically the final lining has a thicknesses between 30 cm and 50 cm, in special cases it might be more. Tunnels are concreted in sections of about 10 m to 12 m. The invert is concreted first, followed by the arch using mechanized formwork. A release strength of about 10 N/mm², is normally required for large tunnels.

For economic reasons the aim is to operate on a 24 hour cycle, especially in long tunnels. In this case the concrete must reach the release strength after 12 hours. To avoid unnecessary cracking, the necessary strength development must be achieved reliably.



Betoniervorgang

Fig 2.14: During the concreting



Nach dem Ausschalen

Fig 2.15: After stripping

2.3.2 Strength development

An important property of hardened concrete is the compressive strength. It is determined by a compression test on specially produced specimens (cubes or cylinders) or cores from the structure. The main factors influencing compressive strength are the type of cement, the water/cement ratio and the degree of hydration, which is affected mainly by the curing time and method. The concrete strength therefore results from the strength of the hydrated cement, the strength of the aggregate, the bond between the two components and the curing. Guide values for the development of compressive strength are given in the table below.

Cement strength class	Continuous storage at	3 days N/mm ²	7 days N/mm ²	28 days N/mm ²	90 days N/mm ²	180 days N/mm ²
32.5 N	+20 °C	30...40	50...65	100	110...125	115...130
	+ 5 °C	10...20	20...40	60...75		
32.5 R; 42.5 N	+20 °C	50...60	65...80	100	105...115	110...120
	+ 5 °C	20...40	40...60	75...90		
42.5 R; 52.5 N 52.5 R	+20 °C	70...80	80...90	100	100...105	105...110
	+ 5 °C	40...60	60...80	90...105		

¹ The 28-day compressive strength at continuous 20 °C storage corresponds to 100 %.

Fig 2.16
Strength development of concrete (guide values¹) according to EN 206-1

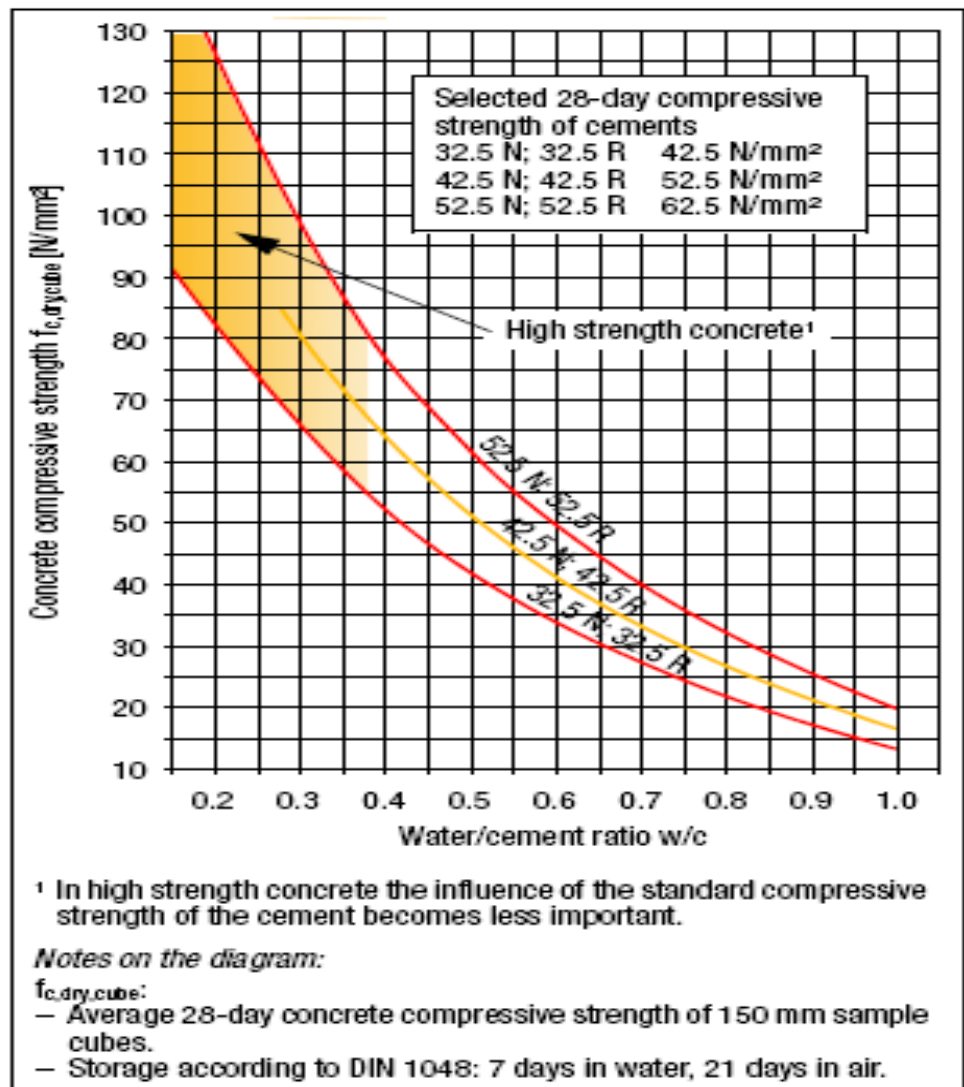

Fig 2.17
Correlation between concrete compressive strength, standard strength of the cement and water/cement ratio

2.3.3 Testing of Concrete Properties

_ General

Certificates of conformity according to EN 206-1 must be provided for other fresh and hardened concrete properties in addition to compressive strength. A sampling and testing plan and conformity criteria are specified for tensile splitting strength, consistence (workability), density, cement content, air content, chloride content and w/c ratio (see the relevant sections in EN 206-1).

_ Fresh Concrete Tests

_ Testing the Consistence by the Slump Test

The fresh concrete is placed in a hollow cone-shaped form and compacted. When the form is raised, the slump gives a measure of the concrete consistence. The slump is the difference in mm between the height of the form and the height of the fresh concrete cone out of the form.

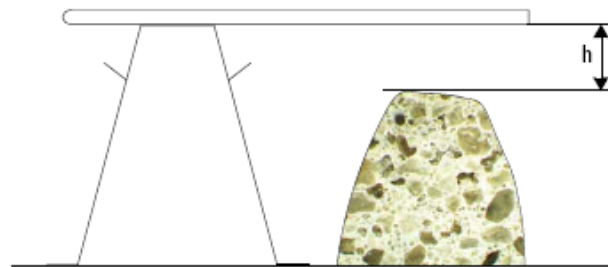

Fig 2.18
Measurement of slump

_ Testing the Consistence by Degree of Compactability

The fresh concrete is placed carefully in the steel test container. Compaction must be avoided. When the container is full to overflowing, the concrete is smoothed flush with the edge without vibration. The concrete is then compacted, e.g. with a poker vibrator (max. bottle diameter 50 mm). After compaction the distance between the concrete surface and the top of the container is measured at the centre of all 4 sides. The mean figure (s) measured is used to calculate the degree of compactability.

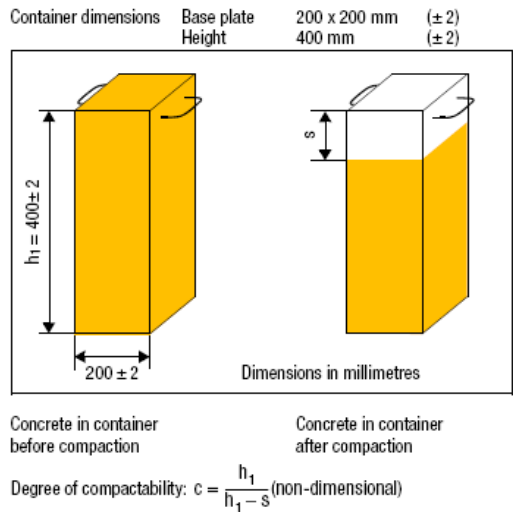

Fig 2.19
Standard EN 12350-4

_ Testing the Consistence by Flow Diameter

This test determines the consistence of fresh concrete by measuring the flow of concrete on a horizontal flat plate. The fresh concrete is first poured into a cone-shaped form (in 2 layers), compacted and smoothed flush with the top of the form. The form is then carefully removed vertically upwards. At the end of any concrete collapse, the plate is raised manually or mechanically 15 times up to the top stop and then dropped to the bottom stop. The concrete flow is measured parallel to the side edges, through the central cross.

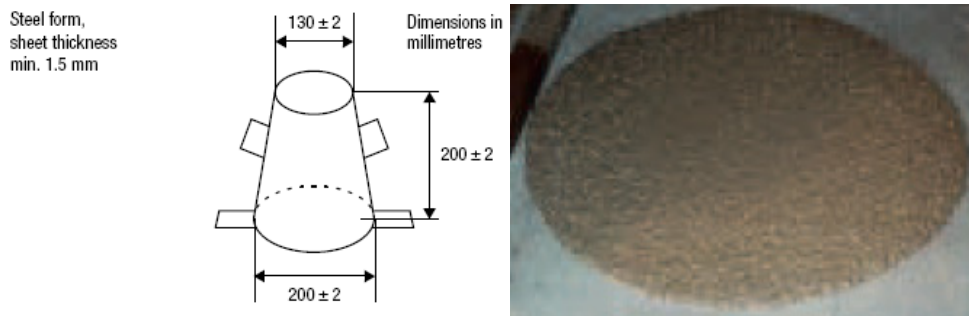

Fig 2.20
Standard EN 12350-5

_ Hardened Concrete Tests

_ Strength testing

Strength can be measured with three tests:

- _ compressive strength
- _ flexural strength
- _ tensile splitting strength

Each strength test result can consist of one or more specimens and average strength is used as the final value. If a specimen is considered faulty, it must be marked and will be left out from the final evaluation.

Testing methods:

- _ Rebound Hammer Test (Schmidt Hammer Test)
- _ 10 to 12 readings are performed per specimen

The test is used to determine the uniformity of the concrete



Fig 2.21: Schmidt Hammer Test

2.3.4 Concrete with enhanced Fire Resistance

Concrete with enhanced or high fire resistance can withstand the defined heat conditions. Concrete itself cannot burn, but above certain temperatures it loses its mechanical properties and then its form. Without special measures, concrete is normally heat resistant up to a temperature of about 80 °C.

The capillary and interstitial water begins to evaporate at temperatures around the boiling point of water (100 °C). Steam needs more space and therefore exerts expansion pressure on the concrete structure. The cement matrix begins to change at temperatures of about 700 °C. The effect of the aggregates is mainly dependent on their origin and begins at about 600 °C. Concrete starts to “melt” at about 1200 °C.

Concrete with high fire resistance is used for

- _ Emergency areas in enclosed structures (tunnel emergency exits)
- _ General improved fire resistance for infrastructure
- _ Fire resistant cladding for structural members

Properties of concrete with high fire resistance

- _ The fresh concrete behaves like standard concrete during placing
- _ The fire resistant concrete has a slower strength development, the other properties are quite similar to non fire resistant concrete

Production of concrete with high fire resistance

- _ The concrete production does not differ from standard concrete
- _ The mixing process must be monitored due to the distribution of the fibres in the concrete mixture
- _ For the future fire resistance of the concrete it is beneficial if it can dry out as much as possible.

3. Sealing

3.1 General

Sealing and dewatering form a functional unit. Two features have to be considered carefully.

- _ A completely tight sealing must be achieved.
- _ After completion of the tunnel, sealing and dewatering system in most of the cases are no longer accessible, except for pipe cleaning.

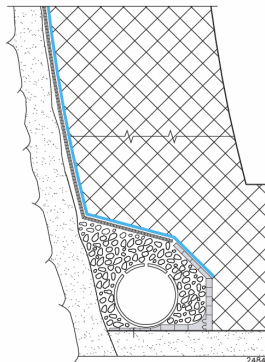

Fig 3.1:
Example for sealing and dewatering

Requirements

Water and humidity can damage the construction. Therefore measures to guarantee the tightness to protect the construction and its equipment have to be taken into account at an early stage of the design. Tunnels normally are in the tightness classes 1 and 2.

Tightness classes	Description
Tunnel	completely dry no humidity spots inside the final lining
Tunnel	dry to humid some humidity spots inside the final lining can be accepted no dripping water inside the final lining is accepted
3	humid some limited humidity spots and dripping water inside the final lining can be accepted
4	humid to wet humidity spots and dripping water inside the final lining can be accepted

Fig 3.2:
Tightness classes

3.2 Sealing concepts

Flexible sealing systems are:

- _ Sealing with polymer-bitumen membranes
- _ Sealing with plastic membranes (PVC, FPO, PE, etc.)
- _ Sprayed sealing
- _ Sealing of the prefabricated concrete segments (tubbings)

3.3 Polymer-bitumen membranes

Polymer-bitumen membranes are mostly used for cut and cover tunnels. The membranes are bonded to the surface of the construction. In mined tunnels it is not applied.



Fig 3.3:
Application of a Polymer-bitumen membrane

3.4 Plastic membranes

3.4.1 Design requirements

The thickness of the sealing membrane amounts for

- _ Non pressing water $\geq 2.0 \text{ mm}$
- _ pressing water $\geq 3.0 \text{ mm}$
- _ rising humidity $\geq 1,2 \text{ mm}$

For crack movements that are larger than the values for the accepted change of crack width below, a joint seal is required.

	Non pressing water		Pressing water	
	with fleece	without fleece	with fleece	without fleece
Crack width	$b_R \leq 0.8 S$	$b_R \leq 1.5 S$	$b_R \leq 0.5 S$	$b_R \leq 1.0 S$
Change of crack width	$\Delta b_R \leq 0.4 S$	$\Delta b_R \leq 0.8 S$	$\Delta b_R \leq 0.2 S$	$\Delta b_R \leq 0.4 S$

b_R = crack width, Δb_R = change of crack width, S = thickness of the sealing membrane

Fig 3.4:
Crack width

3.4.2 Plastic membranes with shotcrete lining

Membranes

With the advent of single shell shotcrete linings, there has also been a request by the industry to provide watertight shotcrete. This is of particular importance with public access tunnels and highway tunnels that are exposed to freezing conditions during winter months, and also electrified rail tunnels. It has been shown that most permanent shotcrete exhibits an extremely low permeability (typically 1×10^{-14} m/s), however water ingress tends still to occur at construction joints, at locations of embedded steel and around rockbolts.

Traditionally, polymer sheet membranes have been used, where the system has been shown to be sensitive to the quality of heat sealed joints and tunnel geometry, particularly at junctions. Furthermore, when sheet membranes have been installed with an inner lining of shotcrete, the following adverse conditions can occur:

- _ As the sheet membranes are point fixed, sprayed inner linings may not be in intimate contact via the membrane to the substrate. This may lead to asymmetrical loading of the tunnel lining.
- _ To aid the build of shotcrete onto sheet membranes, a layer of welded mesh is used. Due to the sheet membrane being point fixed, the quality of shotcrete between the mesh and the sheet membrane is often inferior, and may lead to durability concerns.
- _ The bond strength between shotcrete inner lining and sheet membrane is inadequate and leads to potential de-bonding, particularly in the crown sections of the tunnel profile. This is a detrimental effect when constructing monolithic structures.
- _ As there is little bond strength at the concrete - sheet membrane interface, any ground water will migrate in an unlimited manner. Should the membrane be breached, the ground water will inevitably seep into the inside tunnel surface at any lining construction joint or crack over a considerable length of tunnel lining.

3.5 Sprayable membranes

To overcome these problems, MBT has developed a water based polymer sprayable membrane, Masterseal[®] 340F.

This sprayable membrane has excellent doublesided bond strength (0.8 to 1.3 MPa), allowing it to be used in composite structures, and thereby effectively preventing any potential ground water paths on both membrane–concrete interfaces being created.

Masterseal[®] 340F also has an elasticity of 80 to 140% over a wide range of temperatures allowing it to bridge any cracks that may occur in the concrete structure. Being a water based dispersion with no hazardous components, it is safe to handle and apply in confined spaces. The product can be sprayed using a screw pump and requires two operatives to apply up to 50m²/hr, particularly in the most complex of tunnel geometries, where sheet membranes have always demonstrated their limitation.

As presented in Figure 2.16, in single shell lining applications, Masterseal® 340F is applied after the first layer of permanent fibre-reinforced shotcrete, where the sprayed surface should be as regular as possible to allow an economical application of membrane 5 to 8mm thick (all fibres are covered also). A second layer of permanent steel fibre reinforced shotcrete can then be applied to the inside. As the bond strength between the Masterseal® 340F and the two layers of permanent shotcrete is about 1MPa, the structure can act monolithically, with the sprayable membrane resisting up to 15bar. As this application considers no water drainage, the 2nd layer of shotcrete must be designed to resist any potential hydrostatic load over the life of the structure.

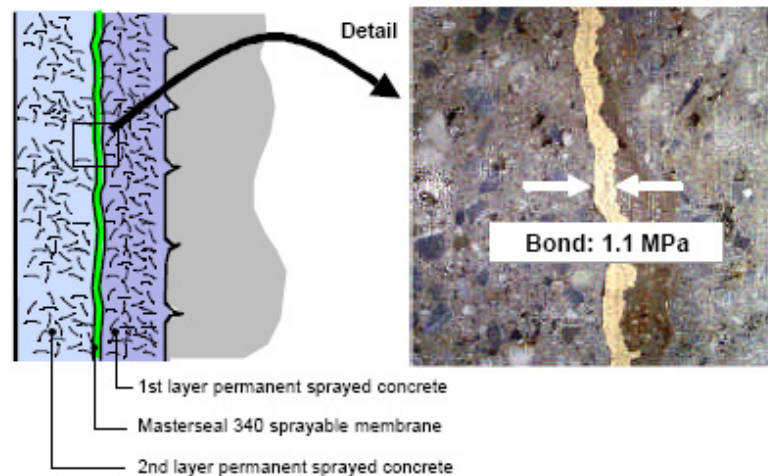

Fig 3.5
Composite, watertight structures using Masterseal 340F sprayable membrane

The minimal thickness of a sprayed membrane is as follows

- _ Non pressing water ≥ 2.0 mm
- _ pressing water ≥ 3.0 mm

For the maximum compression strength a reference value is ≤ 2,0 N/mm². The sealing layers are able to absorb and transmit friction forces. For crack movements that are larger than the values for the accepted change of crack width below, a joint seal is required.

	Non pressing water	Pressing water
Crack width	$b_R \leq 0.3 S$	$b_R \leq 0.2 S$
Change of Crack width	$\Delta b_R \leq 0.2 S$	$\Delta b_R \leq 0.1 S$

- b_R = crack width
- Δb_R = change of crack width
- S = thickness of the sealing membrane

Fig 3.6:
Joint seals against crack width

3.6 Sealing of the prefabricated concrete segment (tubbings)

For sealing the segmental tunnel pipe consisting of individual concrete segments, each segment is provided with a neoprene sealing frame which is glued into the corresponding groove of the ring joints and longitudinal joints. In order to avoid the opening of the seals they have to be compressed in accordance with their load deformation curve. This compression is achieved by means of the application of the thrust forces onto the seals in the ring joint, the subsequent temporary bolting of the segments and the following grouting of the annular gap.



Fig 3.7:
Prefabricated concrete segment (tubbings) with a neoprene sealing frame

4. Repair or replacement of damaged membranes

4.1 General

In Switzerland the sealing of only very few tunnel had to be repaired or replaced. Replacing a sealing in a mined tunnel is only possible if the final lining is removed.

Repair of a leaking sealing membrane in a double shell tunnel is only possible if it has two layers.

4.2 Replacement of the sealing in a double shell railway tunnel

Actually Basler & Hofmann is refurbishing a railway tunnel that has been damaged by swelling rock. The pictures below show the heavy cracks in the final lining and the unprotected sealing (yellow area) between the prefabricated concrete elements and the final lining.



Abb. 4.1
Heavy cracks in the final lining



Abb. 4.2
Damaged sealing membrane in the upper part of the tunnel

On the following drawing, the construction sequences of the repair work is shown. A special challenge is the fact, that all the work has to be done while the trains are passing the site according to the regular timetable at a speed of 80 km/h.

Construction sequences of the repair work

- construction of the safety wall
- construction of the lateral resistance body
- dismantling of the existing final lining
- application of a new sealing
- replacement of the existing final lining

Change to the other side for the same procedure.



Abb. 4.3 Construction sequences for the repair work on the Adler railway tunnel

4.3 Double layered sealing membrane

One possibility for a future repair of a tunnel sealing is to apply a double layered sealing.

For the SBB railway tunnels Zimmerberg and Weinberg that lie below groundwater level, the above mentioned sealing concept has been applied. The two sealing membranes are welded together and the hollow space in between is connected via an inspection and grouting tube to a valve box, where it can be checked. Every chamber can be grouted individually when it is leaking (see figure below).

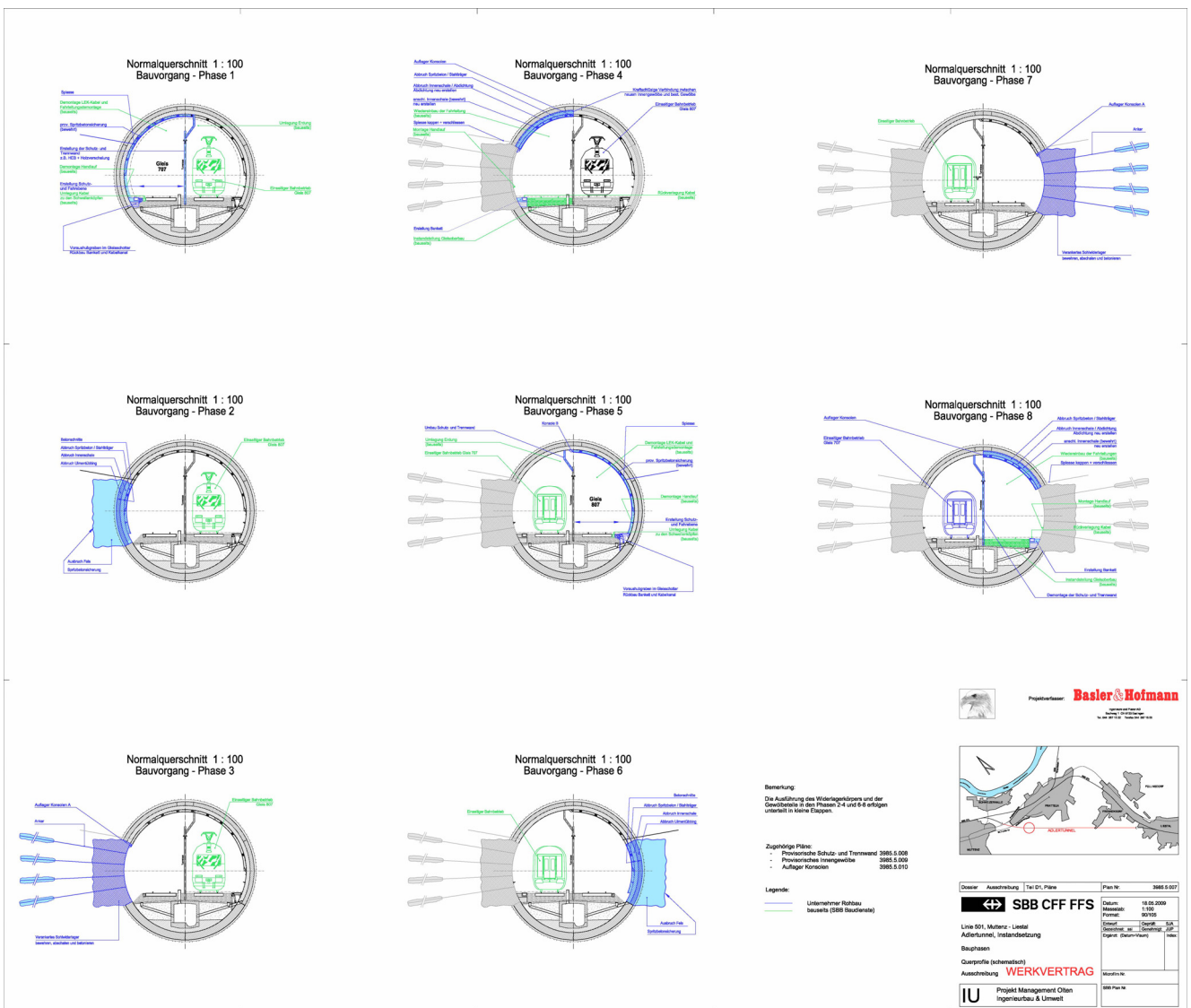
With water pressure

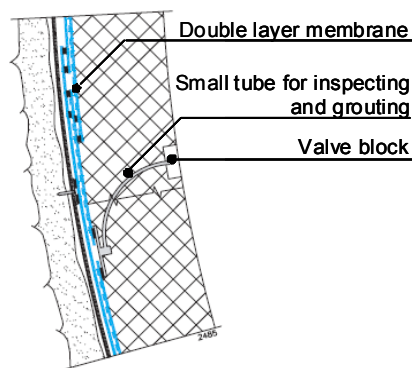

Double layered membrane (groutable)

Thickness of the membrane: d1=3mm, d2=2mm with an additional protection membrane

Material: PVC / PE / FPO

Fleece: 500 g/mm² as an underlay

Abb. 4.4

Double layered sealing membrane for later grouting in case of damages.

5. Typical cross sections

5.1 General

In the sketch below the proposal for the new road tunnel design discussed with the Vegdirektoratet is shown. The idea is to replace the emergency places with one additional emergency lane. Compared to the existing cross section of the type T10.5 the two driving lanes, 3.5 m each, and one emergency lane, 2.5 m, have a total width of 9.5 m. This tunnel design should be the basis for further projects. As shown in the figure below the clearance doesn't allow to realize neither escape ways nor traffic signs because of lack of space on both sides.

The idea is to replace the emergency places with one additional emergency lane. The following cross sections show the specifications according to swiss road tunnel standards and some examples of cross sections that have been realized in Switzerland?

5.2 Cross section of Norwegian tunnel (Vegdirektoratet)

Tunnelklasse T10,5 rette vegger

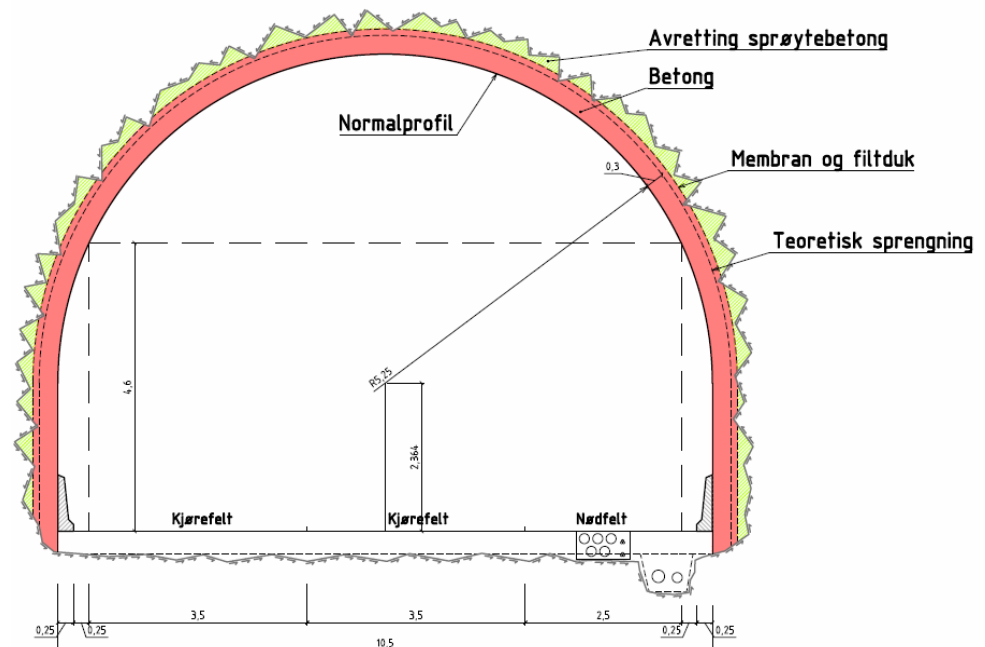

Fig 5.1: Norwegian tunnel class T10.5 with three lanes

5.3 Cross sections of Swiss road tunnels

5.3.1 According to the SIA standards

Nomenclature of Swiss road tunnels

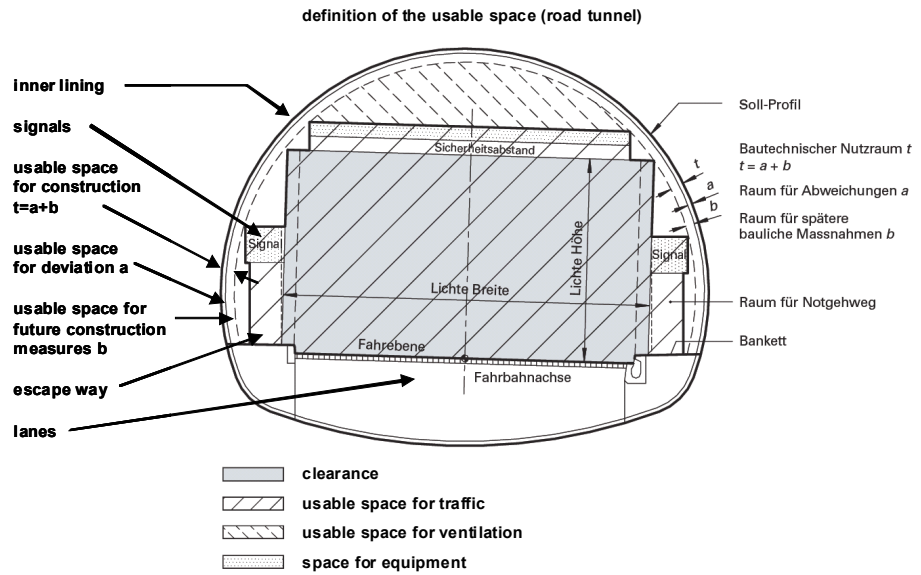

Fig 5.2:
General nomenclature for Swiss road tunnels

Nomenclature of cut and cover road tunnels

rectangular cut and cover tunnel without longitudinal ventilation

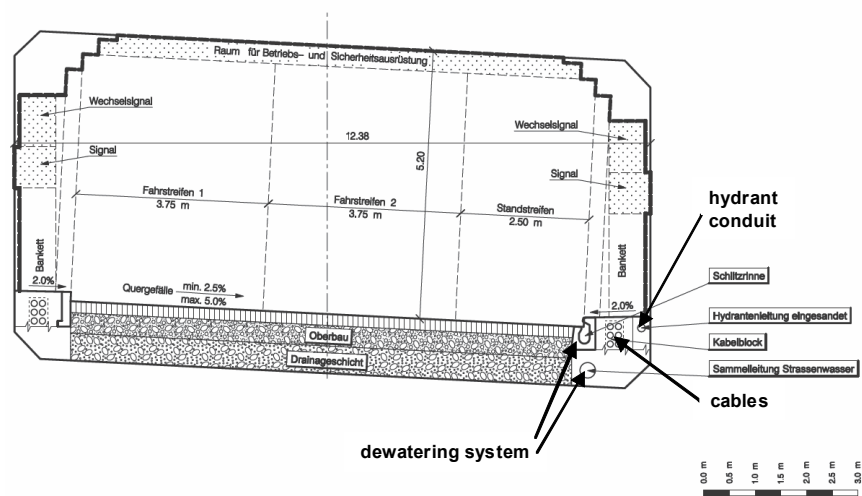

Fig 5.3:
Cut and cover road tunnel

drill and blast road tunnel with exhaustion of air and smoke without invert

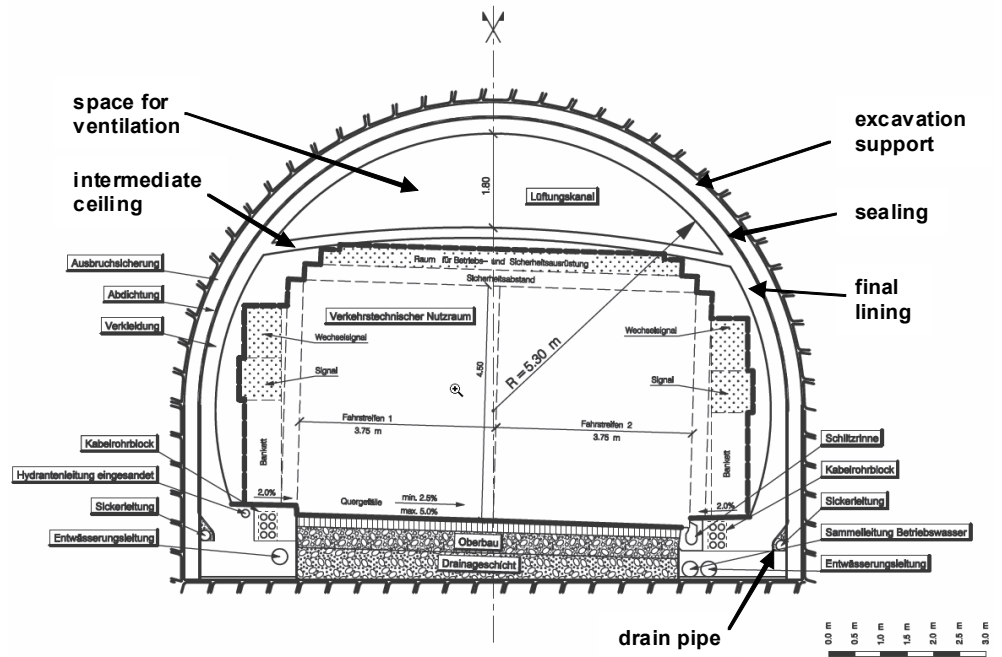

Fig 5.4:
Drill and blast road tunnel

drill and blast road tunnel with longitudinal ventilation and invert

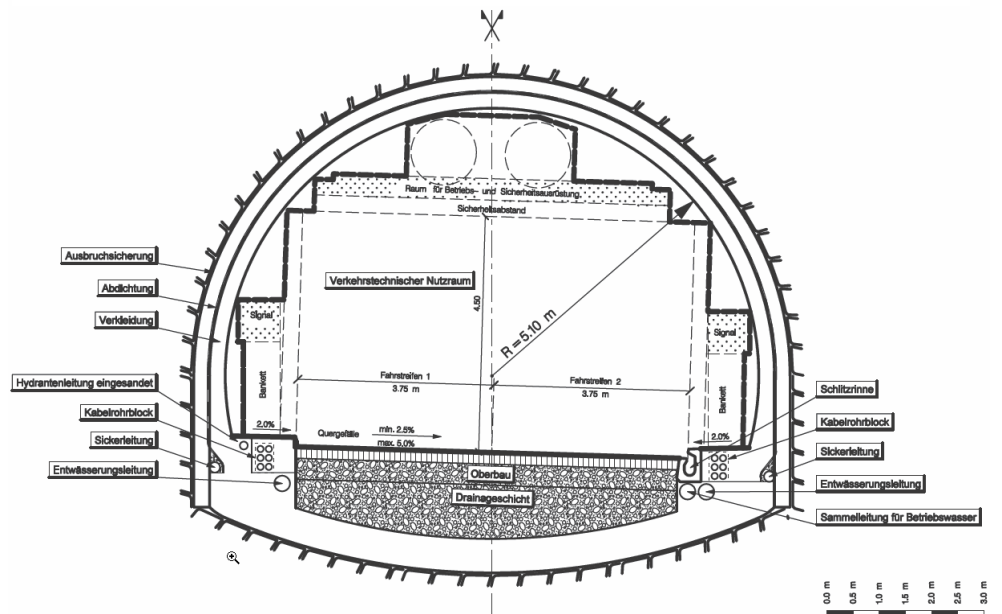

Fig 5.5:
Drill and blast tunnel with invert

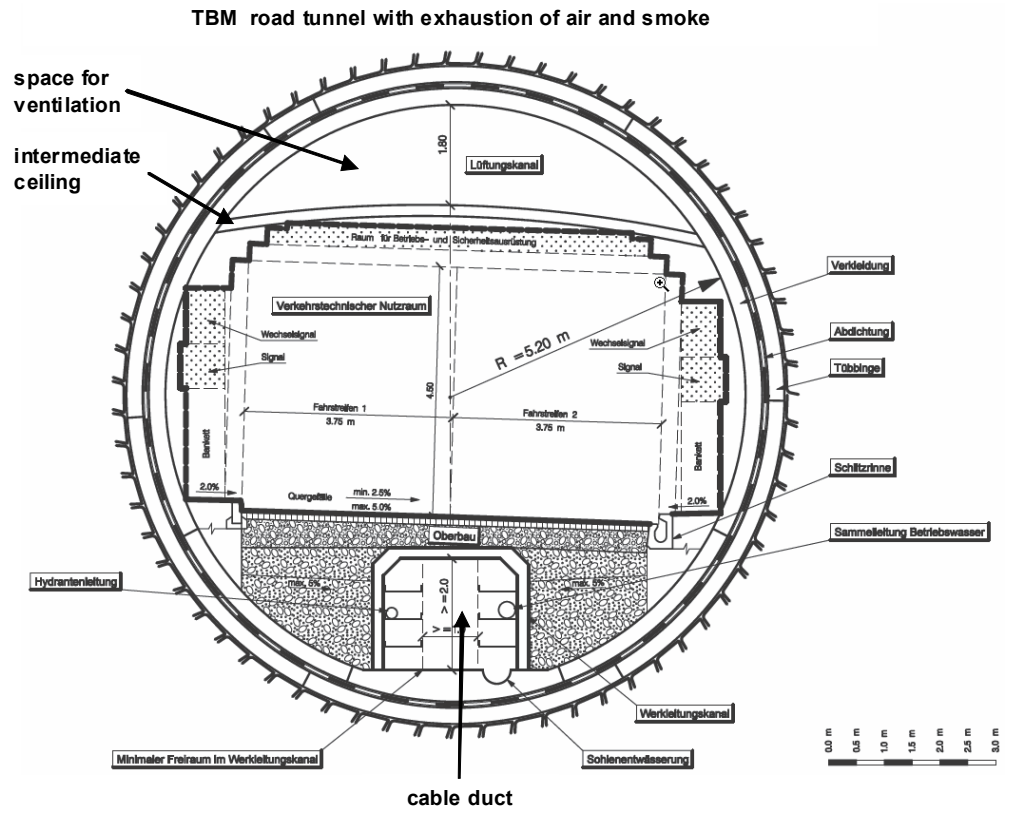





Fig 5.6:
Bored tunnel

5.4 Rules for the selection of the ventilation system

The type of ventilation system depends on the traffic type and the tunnel length:

-  System of the natural ventilation
-  Longitudinal ventilation system with smoke exhaust
-  Cross ventilation system with intermediate ceiling and smoke exhaust

Tunnel with unidirectional traffic and low frequency of traffic jam

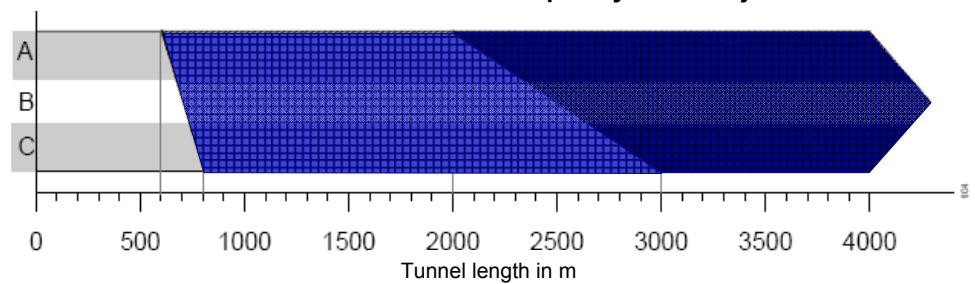

Tunnel with unidirectional traffic and high frequency of traffic jam

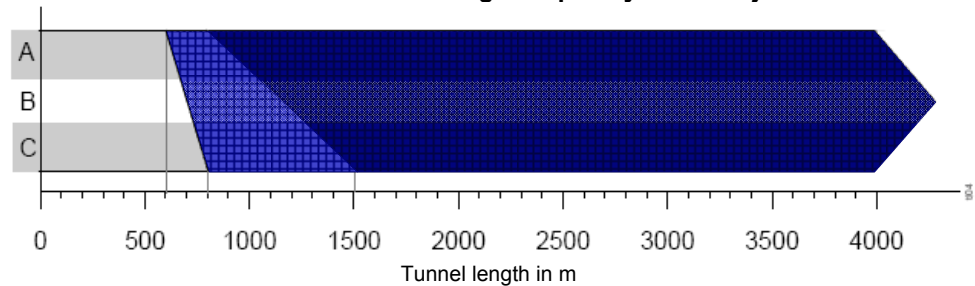

Tunnel with bidirectional traffic

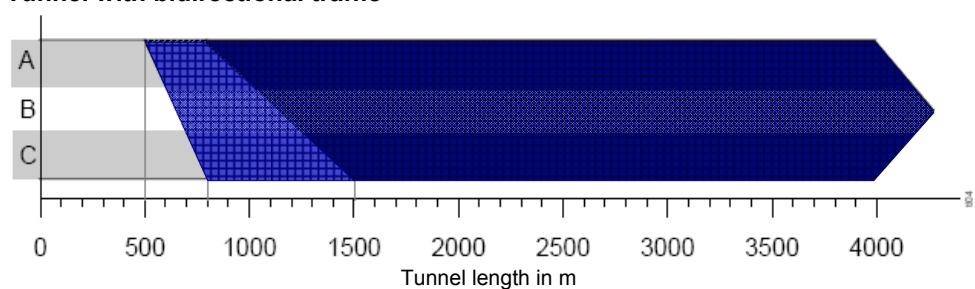

Fig. 5.7:

Definition of the possible main groups of the ventilation systems in safety-related aspects. The specifications are valid for tunnels with a longitudinal gradient until 5%.

According to the Swiss tunnel ventilation standard a road Tunnel with unidirectional traffic and high frequency of traffic jam therefore must have an intermediate ceiling if it is longer than 800 m (class A) and 1'500 m (class C).

If the main group of the ventilation system can not be assigned clearly, the sub-assembly groups (A, B, C) have to be evaluated according to the following criteria:

Overall traffic

Assessment of the Overall traffic	Average daily traffic (ADT) divided by number of lanes	
	One way traffic	Two way traffic
O (high)	> 16'000	> 12'000
M (middle)	11'000 to 16'000	8'000 to 12'000
U (low)	< 11'000	< 8'000

Abb. 5.8
Assessment of the overall traffic

Lorry traffic

Assessment of the Lorry traffic	Number of lorries during 24 h divided by the number of lanes	
	One way traffic	Two way traffic
O	> 1'600	> 1'200
M	800 to 1'600	500 to 1'200
U	< 800	< 500

Abb. 5.9
Assessment of the Lorry traffic

Longitudinal inclination

Assessment of the Longitudinal inclination	Highest value off the average inclination over a distance of 800 m in %		
	One way traffic	One way traffic	Two way traffic
	RV 1	RV 2	GV
O	< - 3	< - 3 and > + 3	> 3
M	- 3 to + 3	- 3 to - 1.5 and + 1.5 to + 3	1.5 to 3
U	> + 3	- 1.5 to + 1.5	0 to 1.5

Abb. 5.10
Assessment of the Longitudinal inclination.

Overall assessment

Overall assessment	Partial assessments
A	O-O-O, O-O-M, O-O-U, O-M-M
B	O-M-U, O-U-U, M-M-M, M-M-U
C	M-U-U, U-U-U

Abb. 5.11
Overall assessment evaluated from the three partial assessments

5.5 Examples of executed Road Tunnels

Swiss national highway tunnel A53, two unidirectional road tunnels with 2 driving and one emergency lanes



Abb. 5.12
Cross section of National highway A53 (drill and blast)



Abb. 5.13
Cross section of National highway A53 (cut and cover)

Swiss national highway A3 Uetliberg tunnel
 Tree lanes 3.5 m each

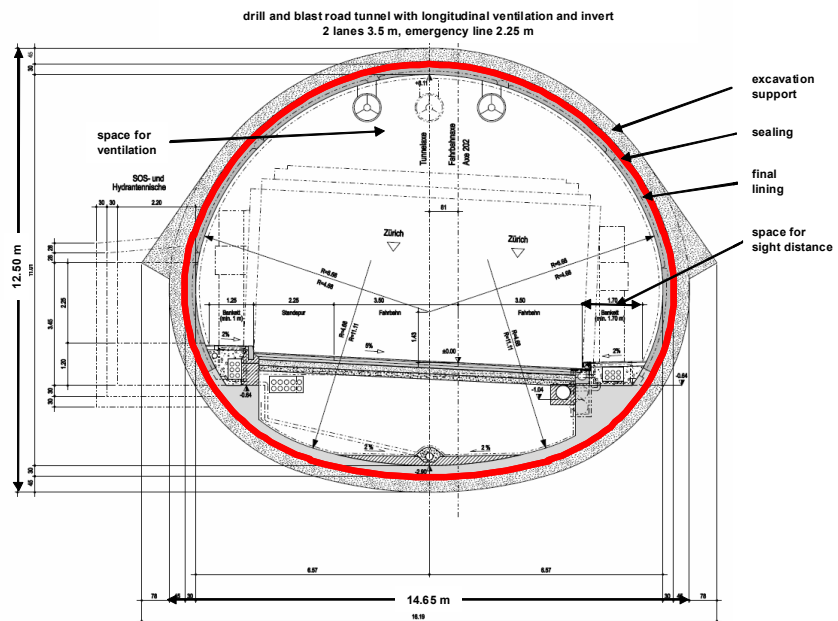

Abb. 5.14
 Cross section of National highway A1/A4 (TBM drive)

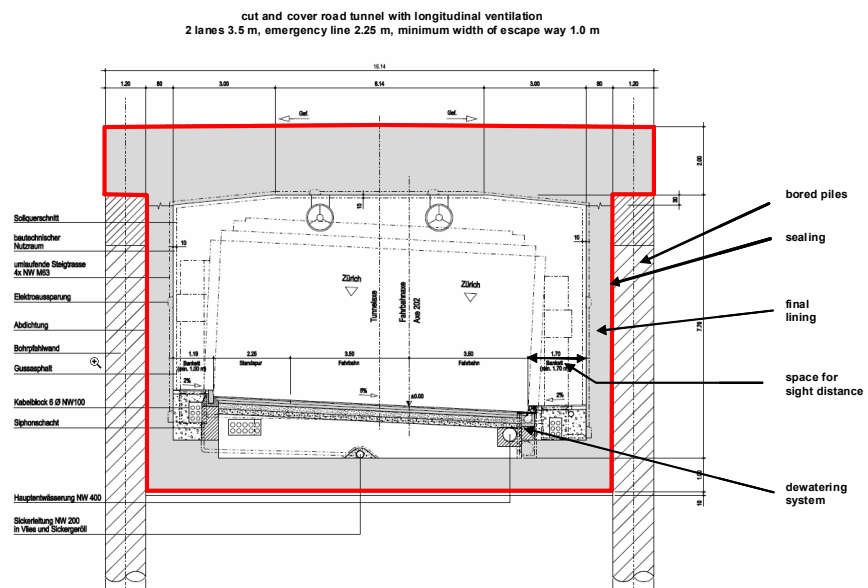
5.6 Swiss standards concerning emergency places and SOS - niches

5.6.1 emergency places

One tube

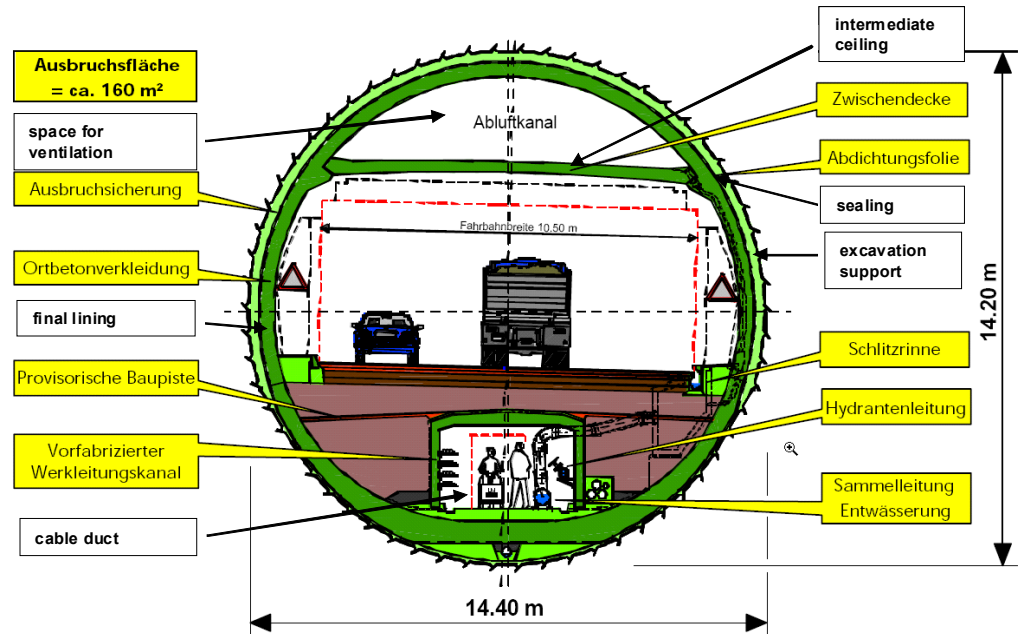
1 tube road tunnel with **bidirectional** traffic:

- every 600 to 900 m two adjacent emergency place (including SOS station and hydrant)
- exception: if there are difficult geological conditions, it is possible to arrange the emergency places in an offset pattern.
- SOS niches every 150 m on both sides
- hydrants every 150 m on one side
- emergency exits (depending on the slope 0 to 5°) every 300 to 500 m
- possible exits:
 - a) open air
 - b) emergency gallery
 - c) fresh air or cable channel duct



Abb. 5.15
Emergency places in single lane road tunnels

Two tubes

2 tubes road tunnel with **unidirectional** traffic:

- no emergency places are necessary
- exception: if the technical station is not reachable from outside the tunnel, an emergency place has to be foreseen in front of the stations entrance
- SOS niches every 150 m on the right side with hydrant
- emergency exit through cross passages (distance less than 300 m)
- in tunnels shorter than 1'200 m one trafficable cross passage
- in long tunnels every 900 m one trafficable cross passage

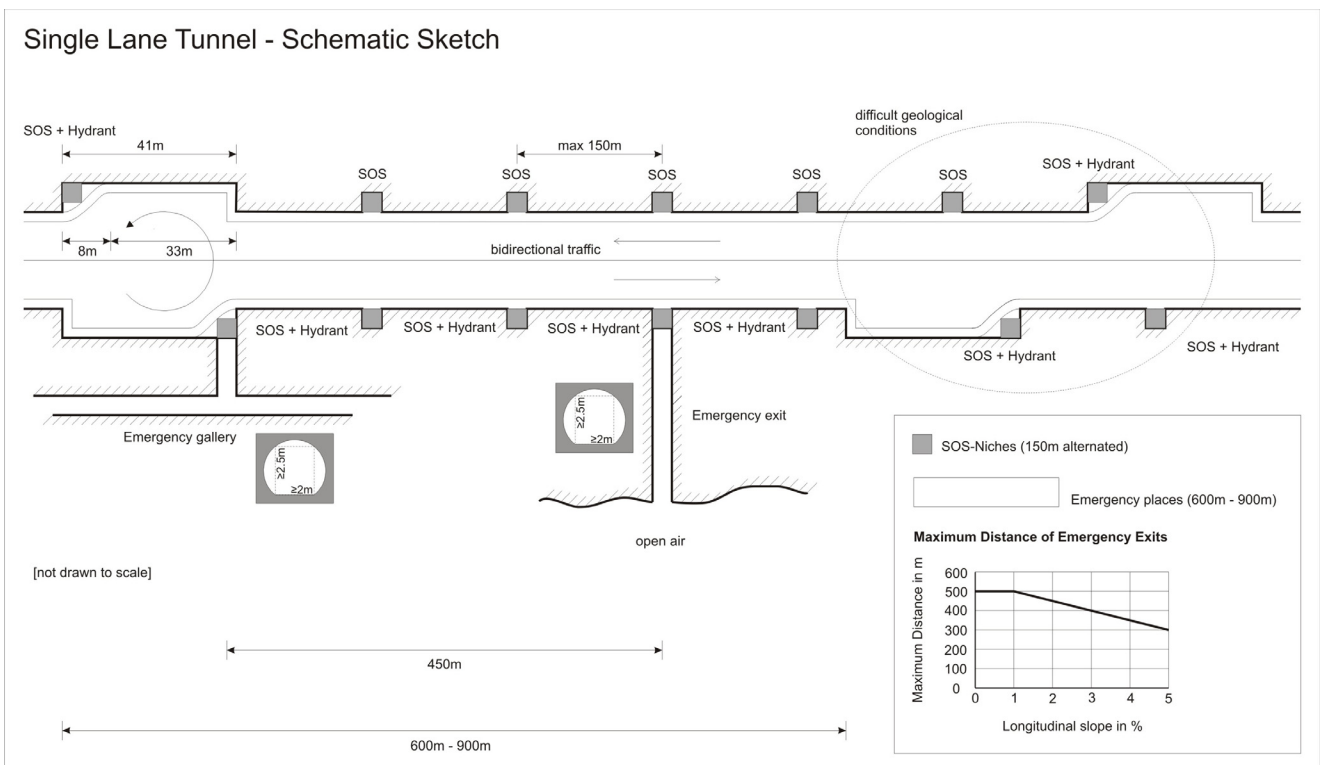

Abb. 5.16
Rescue and escape facilities in double lane road tunnels

Swiss standard dimensions of emergency places

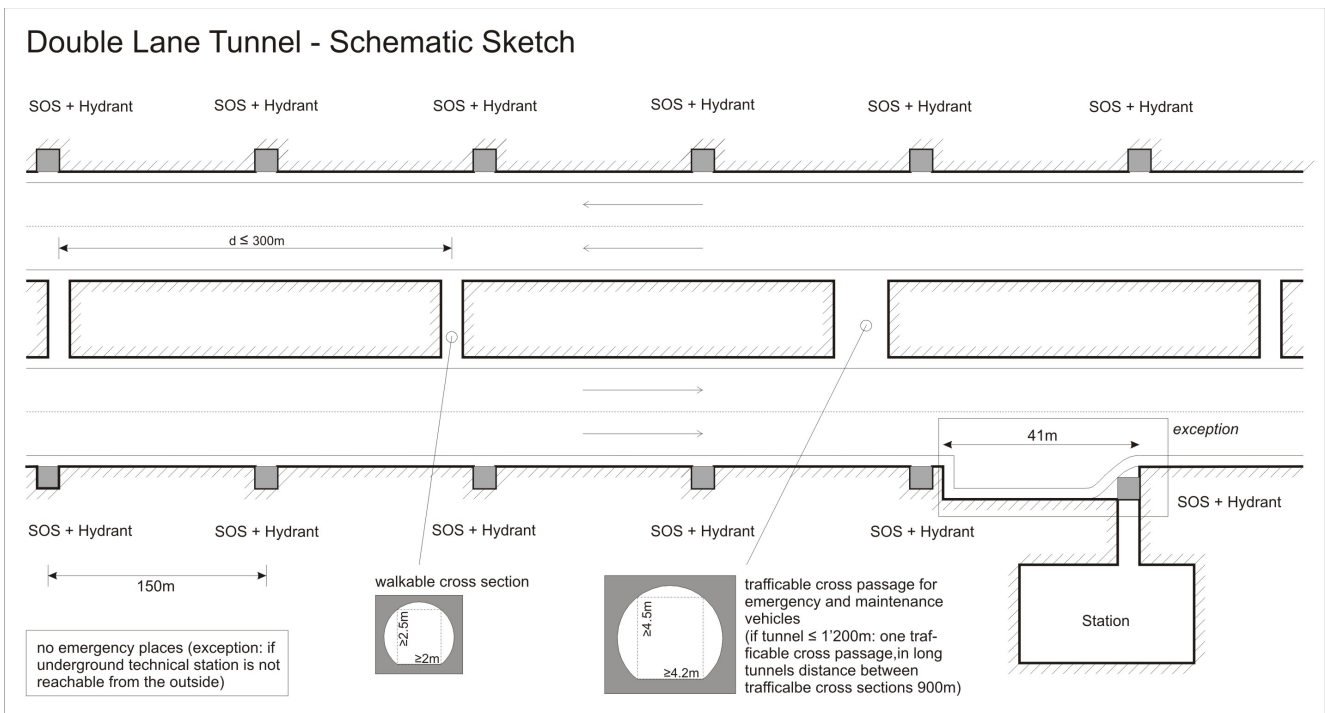

Abb. 5.17
Dimension of emergency places in Swiss road tunnels

Swiss standard dimensions of SOS niches

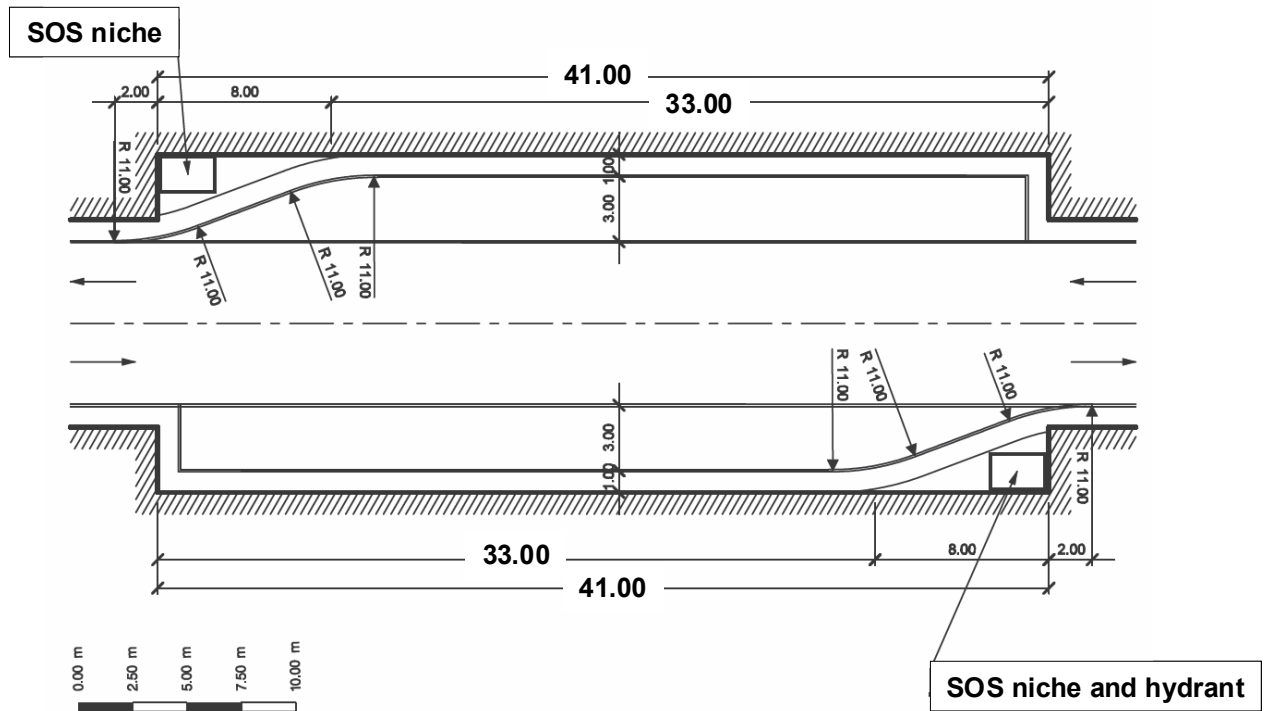

Abb. 5.18
Dimensions of SOS niches in Swiss road tunnels

6. Final remarks

The durability and the serviceability of a tunnel construction depend on a set of measures that have to be coordinated and optimised. Only the entity of all measures guarantee that the expected quality and lifetime can be realised and that the maintenance costs and the obstruction of traffic can be minimised.

In this context, the support construction, the sealing, the dewatering system and the final lining play an essential role in the lifetime of the tunnel construction. Therefore it is worth to elaborate these parts and find robust solutions adapted to the specific conditions.

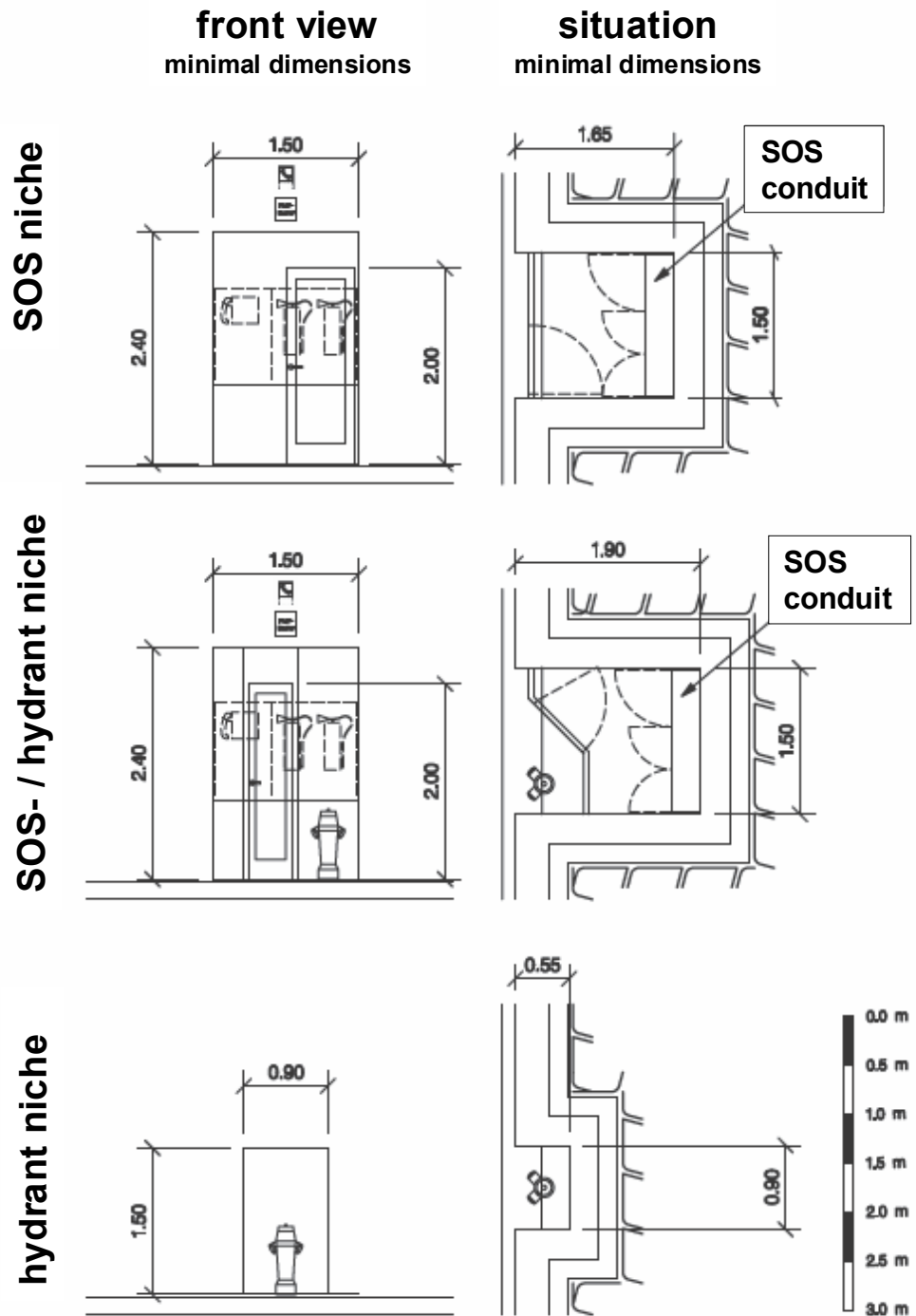
Experiences of carried out tunnels and the assessment of the involved persons responsible for the tunnel maintenance are an indispensable precondition for a successful project. In Switzerland the specified solutions have been applied for more than 30 years and represent a valuable basis for future projects.

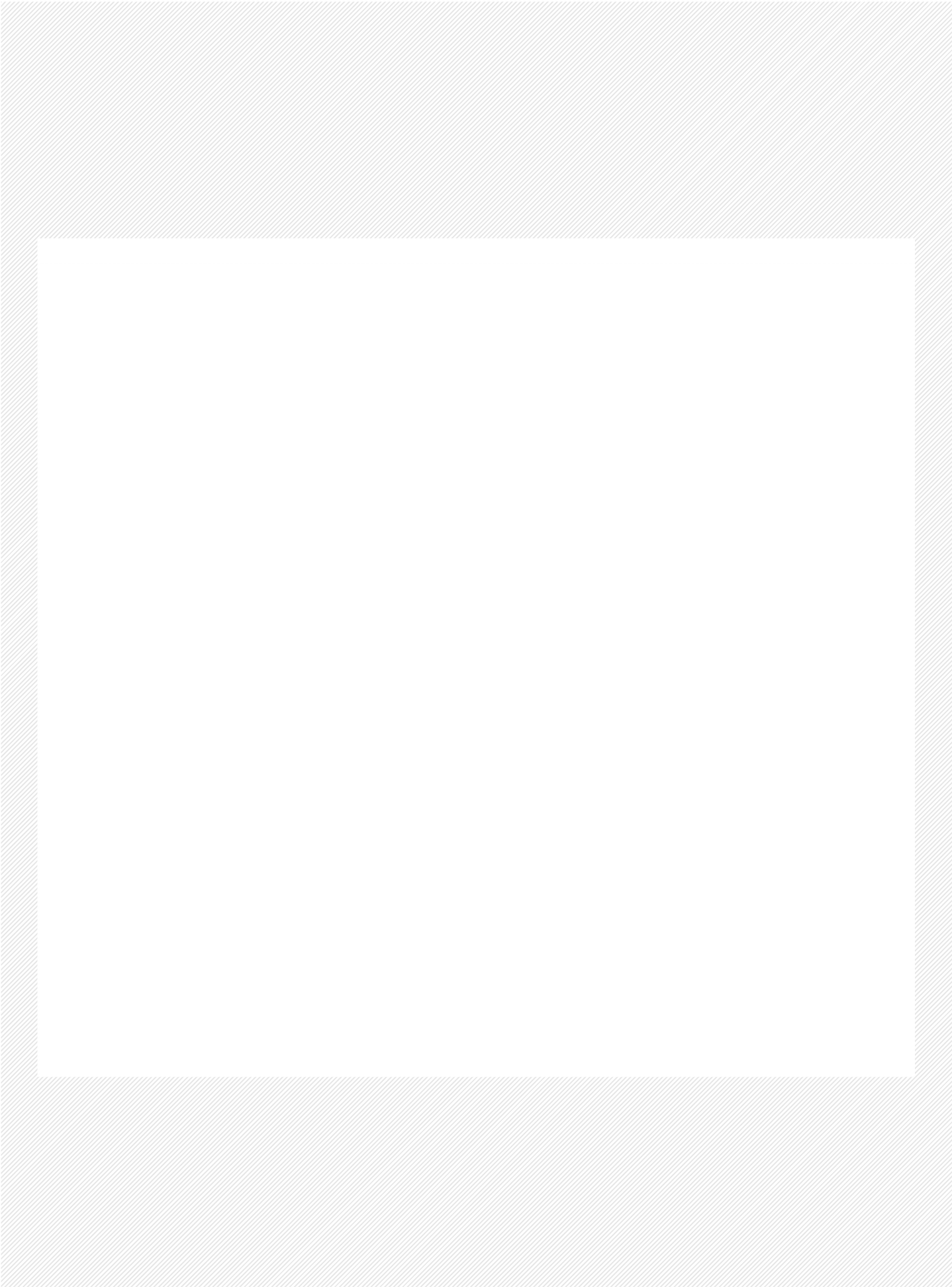



Statens vegvesen

Statens vegvesen
Vegdirektoratet
Publikasjonsekspedisjonen
Postboks 8142 Dep
0033 OSLO
Tlf: (+47 915) 02030
publvd@vegvesen.no

ISSN: 1893-1162